

Charisma



K O S T A S M E T A X A S D E S I G N

Contents

<i>Awards & Innovations</i>	<i>01</i>
<i>3 Decades of "Hi-End"</i>	<i>02</i>
<i>Listening Reference</i>	<i>05</i>
<i>Design Philosophy</i>	<i>06</i>
<i>Operating Instructions</i>	<i>11</i>
<i>What the critics say...</i>	<i>12</i>
<i>Specifications</i>	<i>14</i>
<i>Controls & Features</i>	<i>15</i>
<i>Maintenance</i>	<i>16</i>
<i>Schematic</i>	<i>18</i>
<i>EC Conformity</i>	<i>19</i>

Awards & Innovations

You are about to listen to an amplifier which has evolved from over 20 years of dedicated listening and the application of the state-of-the-art in every process of design and manufacture. I'm sure you'll enjoy listening to it as much as I do.

-Kostas Metaxas DESIGNER



2 X AUSTRALIAN EXPORT AWARD, BHP STEEL DESIGN AWARD,

runner up in AUSTRALIAN SMALL BUSINESS AWARDS

First - Amplifiers- No wire construction with

shortest possible signal path

First - 'Capacitorless' circuits in Audio design

First power amplifier can put full power into

8 ohm load at 1.0MegaHertz!

(refer to article in USA "AUDIO").

First - High Speed diodes in power supply

First - DAC to use lowest jitter 'APOGEE CLOCK'

First - FULL range and high efficiency electrostatic

First - Audio Manufacturer to use BMW-Porsche CAD-PCB

software design systems

3 Decades of Hi-End : 1980's

Opulence Preamplifier



Assembly



Engraving



Ecstatic & Revelation Electrostatics



Kostas Metaxas circa 1985



Soliloquy Monoblocks



3 Decades of Hi-End : 1990's

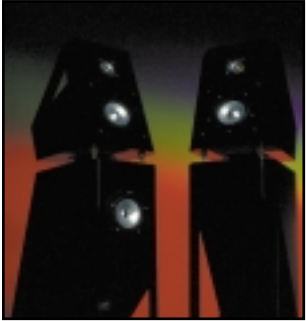

Apollo Speaker

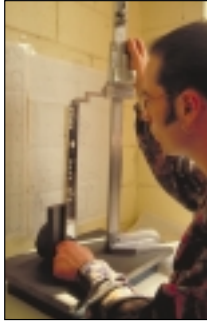

Stainless Steel Turret Punching

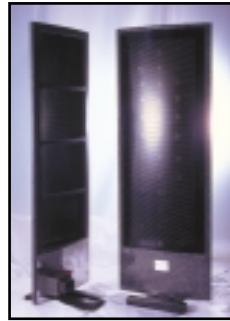

Empress Full-range electrostatics using plastic-composite moulded frame



Iraklis "on-test"



PCB design



EMPEROR Assembly

Reference System circa 1992



Assembly



Assembly



Opulence, Marquis & Charisma Preamplifiers



CZAR 2-way full range electrostatic



3 Decades of Hi-End : 2000's

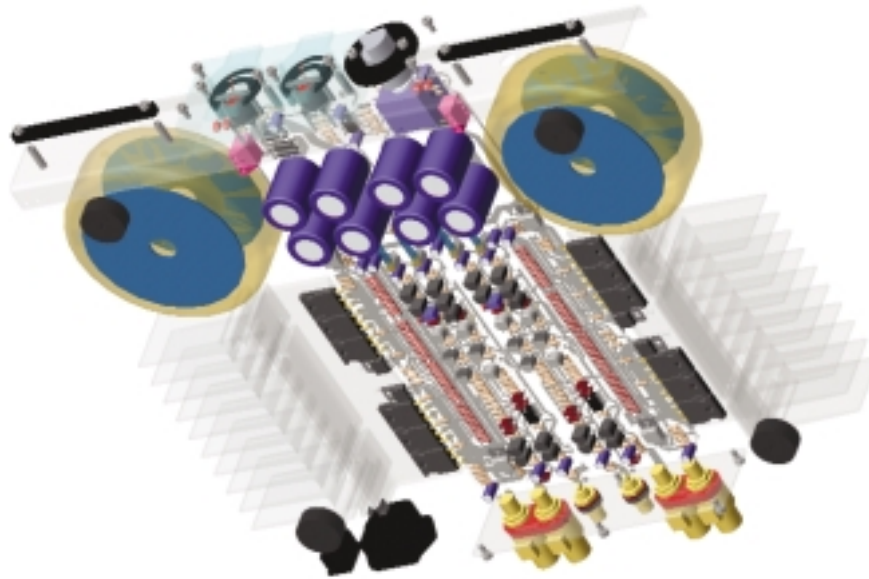

Using technology borrowed from Aerospace and Formula 1, the new Kostas Metaxas Audio designs reflect the extraordinary advances that have been made recently in modelling and simulation software.

For the first time, a High End Audio manufacturer offers audiophiles a rare glimpse into the conception, design and execution of a complete product on a component by component basis in 3D.

The Protel PCB software [www.protel.com] extends the quite normal listening tests on a component by component level to the PCB level.

Schematic Based simulations can test [or verify] the PCB's signal integrity by running the "Signal Integrity Simulator" which displays a Reflection and Crosstalk Analysis. And the 3D visualization allows one to include the PCB as part of the overall wholistic design.

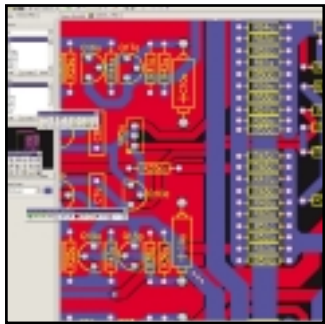

Schematic Capture & PCB design

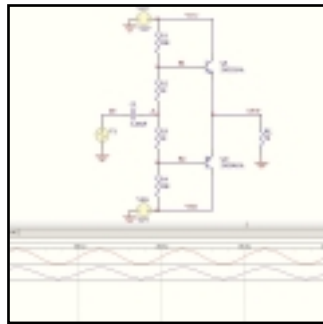

Schematic "Spice" Circuit Simulation

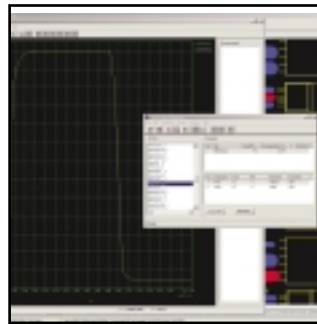

PCB Track Risetime & Slew rate signal integrity testing.

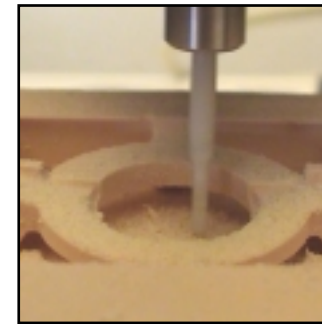

In-house RAPID PROTOTYPING



Laser Engraving

Listening Philosophy

REFERENCE



The only way to design state-of-the-art audio equipment is to have first-hand experience with the finest available recording equipment AND playback equipment.

This is important for two reasons; it ensures that our designs work and 'mate-well' with other products and that their resolution is not limited by the weakest link in the playback 'chain'.

Kostas Metaxas products have been conceived using extensive listening tests with a variety of state-of-the-art ancillary equipment for more than 25 years.

Our amplifiers have been designed using a variety of state-of-the-art phono playback equipment and our ABSOLUTE REFERENCE - a custom-made battery-powered Stellavox SM-8 Tape Recorder using 1/4" tape at 30 ips and a Stellavox TD-9 using 1/2" tape at 30 ips specially calibrated for the Bruel & Kjaer 4003 1/4" omnidirectional electrostatic instrumentation microphones.



Design Philosophy

ULTRA-SHORT SIGNAL PATH : NO-WIRE DESIGN

*A prominent audio designer once described an amplifier as "A straight piece of wire with gain". We take this further by featuring the **shortest** possible signal path in a commercial amplifier. We do not use wire in any of our signal paths and every component is directly soldered to one large printed circuit board.*

From input to output, the signal passes through no more than 150mm of P.C. track. The transformer is connected with only 40mm of wiring to the PC board. This is only possible with our unique construction which features the complete amplifier (including filtering capacitors) is assembled onto one single rectangular Printed Circuit Board where the four sides connect directly to the inputs and outputs, power transistors on their heat sinks and power transformer.

*The audio signal passes through **ONLY ONE TYPE OF WIRE** which is the high speed, wave controlled oxygen free copper of our PC board.*

HIGH SPEED POWER SUPPLIES

Every power amplifier uses a large, high-current power transformer which feeds a 'high-current' bridge rectifier to convert the AC from the transformer into DC voltages which are then mains ripple filtered using massive, computer grade capacitors.

The rectifier bridge that is normally used is relatively large, handles high current and low voltage which slow switching speed because of its inherent high internal capacitance.

It has a response time measured in milliseconds which if converted to frequency would mean that it would have a frequency response from DC to around 100Hz .

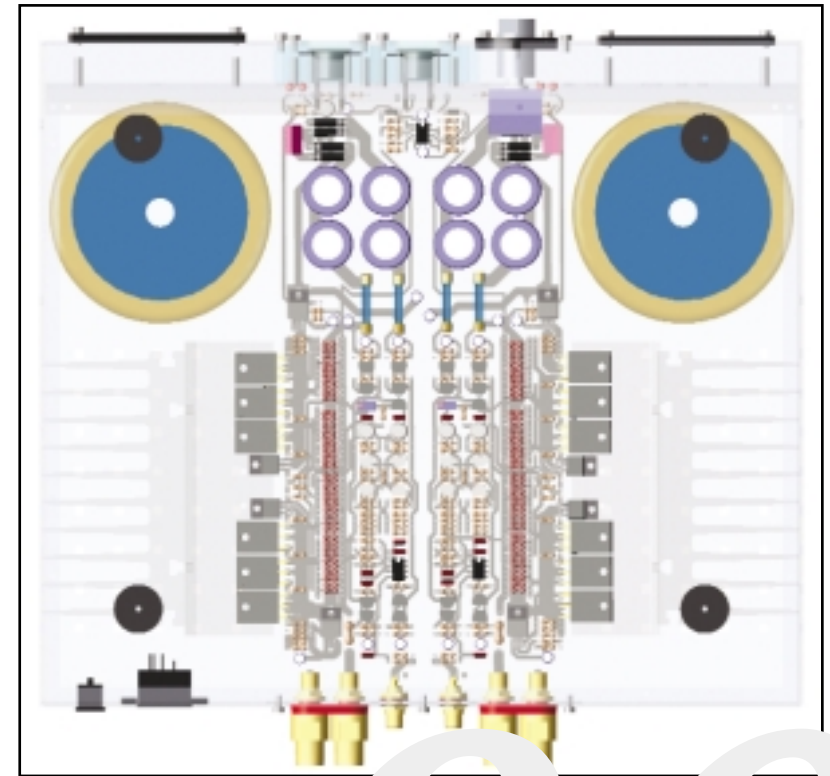

Frequencies above 1 kHz would be unable to draw current instantaneously from the power transformer and would need to rely on the charge stored in the power supply filtering capacitors. We replace this slow DC rectifier with ultra high speed diodes wired in parallel with switching times in 'nanoseconds' which when converted to audio frequencies have a frequency response from DC-10 MegaHertz. High and low frequency currents can be drawn from the power supply more effortlessly .

Design Philosophy

LOW NOISE, HIGH SPEED VOLTAGE REGULATOR DESIGN.

The most significant difference between VALVE and TRANSISTOR circuits is the amplifier/power supply interaction.

In VALVE amplifier, the high voltages (from 200-400 Volts DC) result in a 50,000 to 100,000 Ohms value for resistor R. The equivalent transistor amplifier using much lower voltages (from 12-30 Volts) would have a substantially lower value of R between 200 Ohms-100 Ohms. Therefore a normal power supply in a transistor amplifier is more likely to affect the transistor amplifier circuit compared to a Valve amplifier circuit.

If we assume that the regulator impedance at V+ is around 2 Ohms just for the purpose of this illustration, then let us study the amplitude of the 10 VOLT sine wave as it goes through R and returns back to the OUTPUT of the TRANSISTOR circuit and VALVE circuit.

In the VALVE circuit, when 10 VOLTS travels across the 50,000 Ohms R towards the power supply impedance of 2 Ohms, the 10V signal is attenuated $50,000/2 = 25,000$ times. Therefore $10V/25,000 = 0.0004$ Volts of 1,0kHz sine wave.

On its way back to the OUTPUT of the circuit it is attenuated by the impedance of the amplifier (say 100 Ohms): $0.0004 \text{ Volts}/50,000/1,000 = 0.000008$ Volts. Therefore, 0.000008 VOLTS of out of phase sine wave accompanies the 10 Volts sine wave as out-of-phase distortion in the VALVE CIRCUIT.

In a normal TRANSISTOR circuit, the 10 VOLTS going across the 200 Ohms resistor R would be attenuated only $10/200/2 = 0.1$ VOLTS. On the way back to the output, the voltage is attenuated by: $0.1V/200/1000 = 0.05$ VOLTS of out-of-phase sine wave added to the 10 VOLT output sine wave.

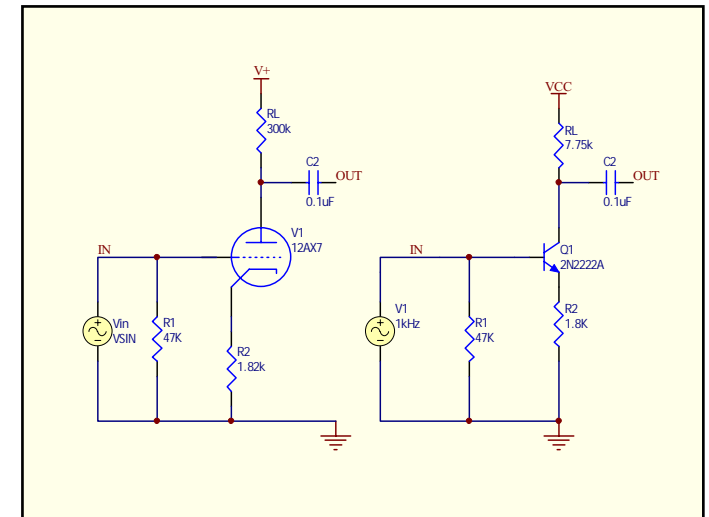

Design Philosophy

In a normal Transistor circuit, the 'phase distortion' is 0.5% as compared to 0.000008% for a normal VALVE circuit .

If we monitor the V+ point of the transistor circuit using an oscilloscope, we would notice this 0.1 Volts, 1.0 kHz signal. If we were to increase the frequency to 10,000 Hz and up to 1.0 MegaHertz the speed of dynamic behaviour of the power supply becomes critical. Using a normal I.C. regulator would result in the signal at V+ actually increasing in amplitude as the frequency increases to that at 1.0 MegaHertz the 1.0 Volt sine wave is now over 1.0 Volt!

To fully understand this interaction between the amplifier and power supply, it is necessary to understand how a voltage regulated power supply works. A voltage regulated power supply is essentially a D.C. amplifier (not unlike a normal power amplifier) which instead of having an audio signal at the input which is then amplified to become a larger audio signal at the output, has a fixed D.C. voltage reference at the input which is then amplified and becomes a larger DC voltage of at the output. The output impedance of the regulator, not unlike the output impedance (or "Damping Factor") of a power amplifier is less than one ohm at D.C.

If we use a 2.0 Volt zener diode as our fixed DC voltage reference at the input of the D.C. amplifier which has a gain of 10, the resulting output voltage is 20 Volts D.C.

The negative feedback loop of the amplifier which fixes the gain of 10 times the 2.0 Volt zener reference is very important because it maintains the output voltage irrespective; of an increase or decrease in the power supply voltage to the amplifier as long as there is a minimum voltage for the regulator circuit to operate (for a 12 Volt regulator, the minimum voltage is 15 Volts).

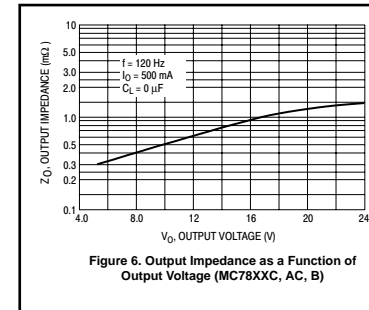

Figure 6. Output Impedance as a Function of Output Voltage (MC78XXC, AC, B)

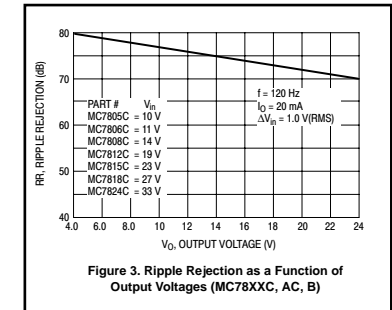

Figure 3. Ripple Rejection as a Function of Output Voltages (MC78XXC, AC, B)

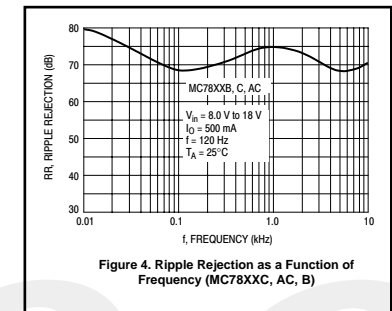
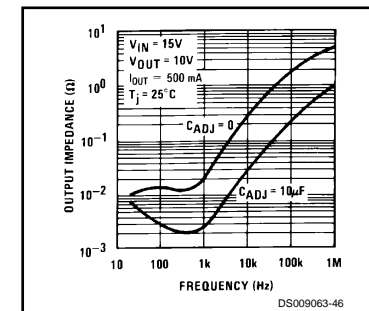

Figure 4. Ripple Rejection as a Function of Frequency (MC78XXC, AC, B)

Design Philosophy

This is the STATIC performance of a voltage regulator which although important, does not affect the overall sound of the amplifier as much as the regulator's DYNAMIC performance which is influenced by the speed and 'open loop gain' of the regulator.

To understand why the Dynamic performance of a voltage regulator is so important, we need to go back to our basic amplifier circuit and investigate what happens to the 1.0 Hz, 10 Volt output signal as it goes across resistor R and encounters our voltage regulator.

To ensure an absolutely stable D.C. at V+ the residual of the 10 Volt sine wave at the OUTPUT is fed through the negative feedback loop of the regulator to force the amplifier to correct this error by applying an inverted signal identical to the residual sine wave to totally eliminate the residual sine wave at V+. A high speed regulator would therefore treat a signal 1.0 Mega Hertz in the same manner as a signal at 1.0kHz. The ultimate voltage regulator would effectively have a theoretical output impedance (or 'Damping Factor') at V+ of zero ohms at all frequencies as a result of its wide bandwidth before the addition of negative feedback.

In this way, the attenuation of the 10 Volts across the resistor R residual would be complete, and no attenuated component of the 10 VOLT sine wave could be deflected and return to the OUTPUT of the circuit and cause severe phase anomalies by adding to the new signal presented at the output - remember that it would take a few nanoseconds for the signal to go through the resistor and come back.

This extraneous out-of-phase information if allowed to add to the new OUTPUT signal, would then destroy TIME/PHASE characteristics of the amplifier circuit.

In real world power supply circuits, the impedance of the power supply actually increases with frequency because the open loop gain rolls off at high frequencies.

Marquis Voltage Regulator

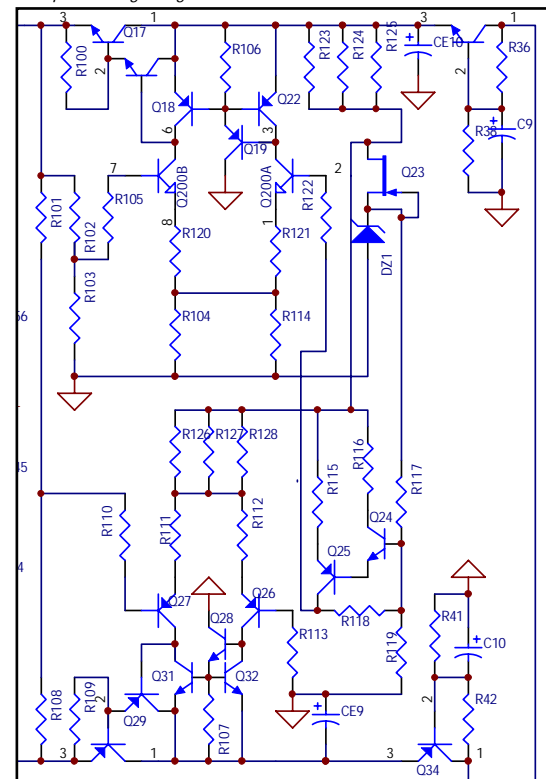

Design Philosophy

If we go back to our basic circuit and analysed the performance of an I.C. positive voltage regulator (say a LM78LXX from NATIONAL SEMICONDUCTORS) it would have an output impedance at the pin of its output lead of around 0.2 Ohms from DC to 10kHz, and then an increase to 0.4 Ohms at 20kHz, then 4.0 Ohms at 1 MEGAHERTZ which clearly illustrates the open loop frequency response has a turnover point around 10 kHz. When you add the normal distance between the regulator output and amplifier circuits which may be as little as 60mm to as much as 200mm in many circuits, the overall impedance increases 5 to 10 times. Also, to stabilise the operation of this I.C. regulator, it is essential to use an output capacitor for stability.

Clearly, this is not good enough for high performance, high speed transistor circuits. For this reason, we have approached the design of our regulators as PART of our amplifier circuits, rather than make the fastest amplifier circuit and add a slow I.C. voltage regulator with an output capacitor and call it a finished design. Our discrete voltage regulators are designed to have the absolute lowest noise, reject mains ripple, but more importantly to have a speed (1000 V/microsecond) which is a result of their wide bandwidth design (an open loop frequency response greater than 500kHz) and output impedance which is an order of magnitude better than any I.C. The regulator stability is achieved without ANY capacitors by varying the ratio between the local and overall feedback of each device.

We position the regulators within inches of the active circuits (in the case of the OPULENCE, the regulator is 3mm! from the active circuits) and the regulator impedance is flat from DC to beyond 5 MegaHertz at less than 0.05 Ohms.

Beyond this electrical design aspect, we listen to the sound of our regulators whilst developing each amplifier circuit to ensure that every component change or substitution produces an audible improvement from the selection of transistors to best biasing currents, choice of voltage references zeners and degree of local feedback.

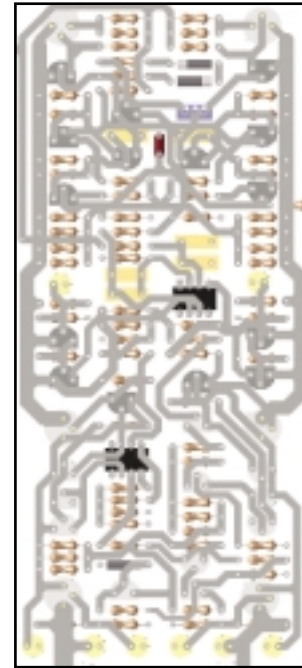

Marquis "wholistic" approach to Line Stage/Regulator

Operating Instructions

Steps for Connection

1. Ensure that the ON/OFF switch on the back panel is in the OFF position before connecting the amplifier into your system.
2. Once connected, ensure that there are no 'short circuits' in the speaker wires, then proceed to switch the unit ON.

Note: For the best results, it is recommended that the unit is powered on for at least 15 minutes before critical listening is attempted.

DC Protection Circuits

The output stage of the preamplifier is connected to a DC protection circuit which activates a relay if it senses any DC before it can cause any damage to your speakers.

Mains Fuse

A 2AMP SLOW BLOW DA205 Type fuse is located on the AC MAINS SOCKET. If this blows, simply replace with the same rating fuse. If the fuse continues to blow, please refer to the Maintenance Section of this manual for further instructions.

Serviceability

The complete active circuitry of the amplifier including primary filtering capacitors are all mounted to the large single ground P.C.B. Easy access to the board is maintained by simply removing the base to gain access to the 'component side' for servicing.

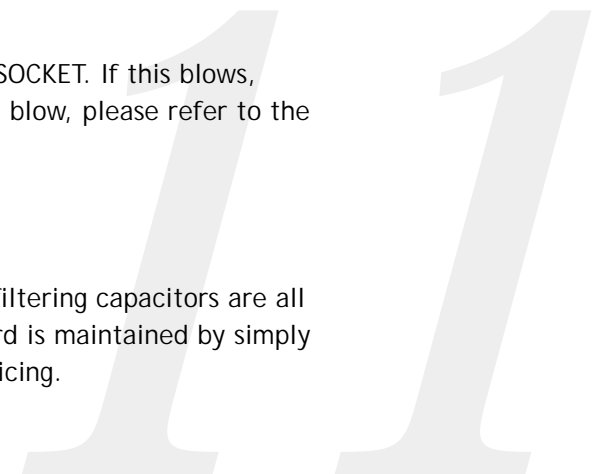

What the critics say...

"The Metaxas analyses the message with a fantastic precision; it is able to reveal a great deal of micro-information which is normally difficult or almost impossible to hear. According to us, the Charisma is a step towards a true and available High Fidelity without compromise".

Jean Hiraga/Patrick Vercher, LA NOUVELLE REVUE DU SON, France.

"I also found that I clearly preferred the Metaxas with a vinyl source. Music seemed less clinical though it was as detailed and informative as with a line level source. Vocalists were more characterful, realistic and convincing".

Malcolm Steward, AUDIOPHILE England.

" The Metaxas gave an effortless, polished sound for choir recordings and reproduced voices very smoothly without the slightest trace of harshness. One almost felt reminded of an excellent tube amplifier":

M. Kucera, SOUND MAGAZINE Switzerland.

" We auditioned the Charisma using recordings with large orchestra arrangements as well as the small ensembles-all with the same results: three dimensional, life-like musical performance within realistic acoustical boundaries. "

Ernie Fischer, THE INNER EAR REPORT, Canada.



" ... because of the stress laid on it in the literature, I spend some time listening via the phono input to several alternative pickup cartridges, thus renewing acquaintance with a number of long forgotten LP's to which it did full justice".

Geoff Horn, GRAMOPHONE, England.

What the critics say...

"Between the poles-not extremes, lively walks Metaxas without caring about the esoteric space or the drive of others, but also without denying his own character, namely not to drown everything in neutrality. Between Italy (CABRE) and Tokyo (ROTEL) the mids are where the Metaxas duo (Charisma/Iraklis) are unique; lots of tonal colours, body, drive finish, precision and impulsivity... recommended for the years without vinyl."

Ulrich Michalik, HI FI EXCLUSIV, Germany.

"With more sense for the finer things, but not without liveliness, thus in summary most consistently, present the amps of Kostas Metaxas themselves. Combined with the right speaker, they can please both ear and eye."

Dirk Sommer HI FI EXCLUSIV Germany

"The overall sound is undoubtedly both fascinating and convincing, half way between the crystalline purity and imaging of the best solid state components (mid and high frequencies) and the velvety personality of high class valve units (for example Conrad Johnson)".

Gianfranco Machelli STEREO, Italy.

"When going back to our reference preamplifier (after listening to the Charisma), the sound was less sweet and a little sterile".

Klaus Renner DAS OHR, Germany,

"It is a very smooth-handling unit, as quiet and precise as they come, easy to use ... I would have no hesitation in recommending it to anyone willing to spend ... especially anyone who uses a moving coil cartridge, for which the Charisma would seem to be ideal".

Julian Hirsch, STEREO REVIEW, USA.



Specifications

1. LINE STAGE: The Line stage features an identical circuit topology and DC servo amplifier as used in the Phono Stage except that it is optimised for linear frequency amplification. To entirely eliminate the sonic degradation of using a BALANCE potentiometer in the signal path, the BALANCE control is tied via a secondary network to the inverse feedback loop.
2. POWER SUPPLY: A 200W large toroidal transformer, RFI input mains filter and massive 50,000uF of primary capacitance before reaching the regulation circuits.

D.C. regulation is accomplished via a circuit built around two high speed, low noise integrated circuits with discrete voltage reference.

The positive Master circuit derives its positive reference voltage from a selected, low noise zener in an unusual manner - from the regulated output. The negative circuit tracks the positive Master and therefore ensures that symmetrical positive and negative supplies are within millivolts of each other - important in D.C. amplifier designs.

The unique feature of this circuit is that it has been developed in conjunction with the Phono Stage and Output Stage to eliminate the need for stabilising bypass capacitors which store H.F. energy and cause serious sound quality anomalies.

3. DC PROTECTION: A circuit built around a dual F.E.T. Integrated Circuit monitors the left and right output stage and controls a relay in series with the outputs. If a voltage greater than 0.6V DC is sensed, it automatically disables the signal to the outputs and shorts the input of the following Power Amplifier. When the fault is removed, the relay trips back into operation.

Specifications

FREQUENCY RESPONSE : DC - 5.0MHz (-3dB)

VOLTAGE OUTPUT : 15VRMS per channel into 50 Ohms with no more than 0.05% T.H.D.

SLEW RATE : Greater than 1000V/us small and large signal

T.H.D. : Less than 0.05% 20Hz-20KHz

I.M.D. (S.M.P.T.E.) : Less than 0.05%

SIGNAL/NOISE : -117DBV unweighed input shorted

SENSITIVITY : 26dB

INPUT IMPEDANCE : 100kOhms in parallel with 11pF

OPTIONAL RIAA PHONO STAGE:

Input micro switches allow over 69 different combinations of input impedance, whilst the phono input stage can be configured for operation with either Moving Magnet or Moving Coil cartridges. The RIAA equalisation is generated via selected polystyrene capacitors and 1% metal film resistors in the inverse feedback loop.

The overall open-loop gain of this stage has been optimised using local feedback in the voltage gain stages to approximate the RIAA time constants before the application of a minimal amount of overall feedback. This allows us to minimise the stability compensation to ensure the high speed (greater than 10MHz) operation of this circuit.

The DC operating point is stabilised with the use of a low drift F.E.T. input servo Op Amp which feeds micro-volts to the inverting arm of the differential input to entirely eliminate the need for any input or output capacitors in the signal path.

Controls & Features

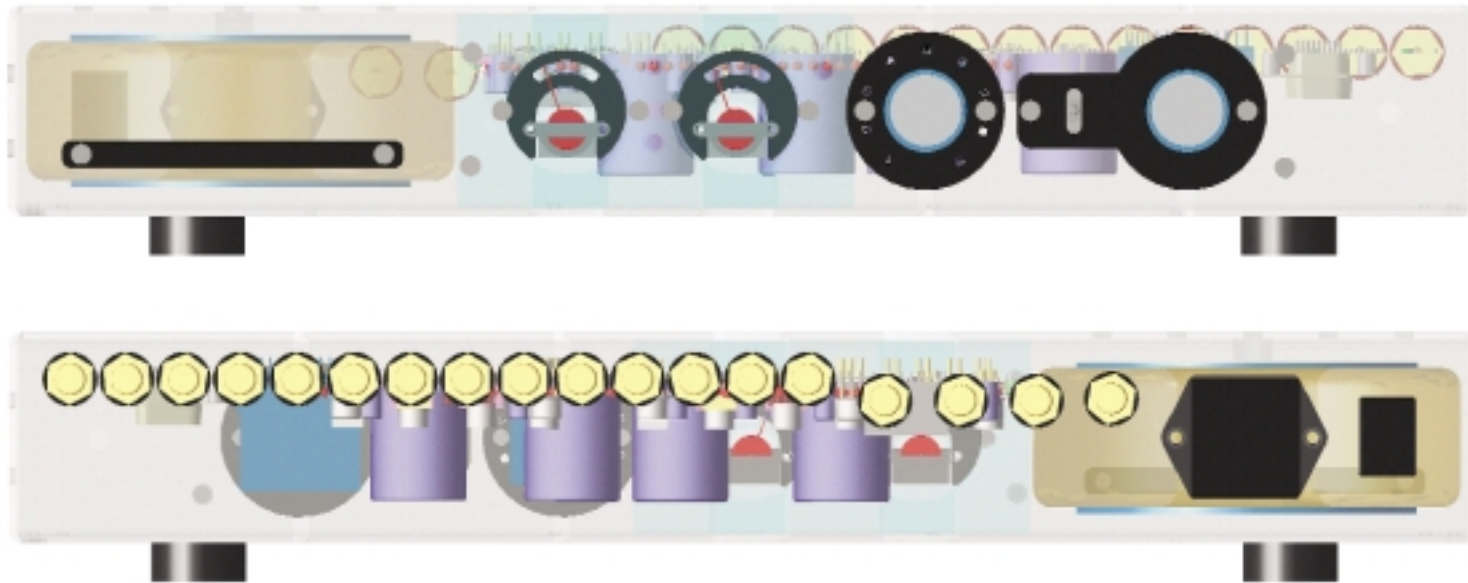

15

Maintenance

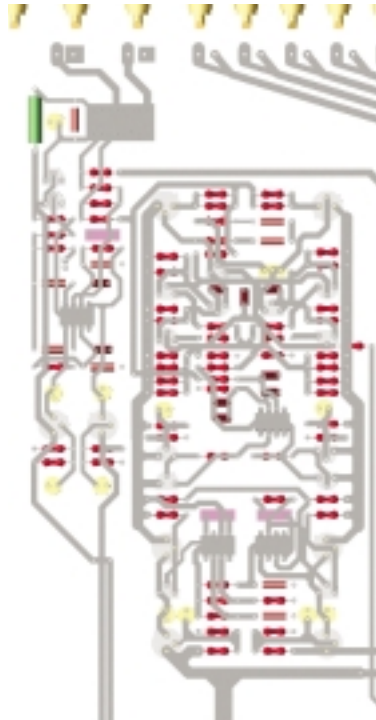

TESTING

1. Connect the + and - supply lines [at the FUSEHOLDERS or RECTIFIER DIODES] to an external current limiting Power Supply with maximum +/- 30VDC output voltage (or use 2 x 30VDC supplies).
2. Rotate the biasing trimpots VR5 & VR5a fully clockwise.
3. Connect the amplifier to a signal source (Sound Technology 1700B or Oscillator) which generates sine waves at 1.0kHz frequency and monitor the input and output on a dual trace Oscilloscope.
4. Power the module on and check that there is no current limiting. You should be able to monitor the amp on the Oscilloscope. (Connect your oscillator to any HIGH LEVEL input, and ensure that MUTING switch is in the UP position, and VOLUME control is at position 9).
5. Measure the voltage drop after the "regulators" [the emitter of Q16, 30] which should be ~20 volts .
6. If voltages are O.K. check the waveform on the oscilloscope, it should show crossover distortion.,
7. Clip a multimeter across any of the 100OHMS output stage emitter resistors [R46,56,55,45] and turn the trimpot anticlockwise until you measure approx. 0.75 VDC across this resistor. Maintain for 30 minutes, adjusting the pot as the amp warms up.
5. DC Offset Voltage at Output. Connect multimeter probes to the intersection of resistors R55 & R56 to measure the DC offset. It should be less than 0.05VDC. If it is greater than this please check the LF351 DC SERVO IC[U1]. Check that they are receiving voltage at Pin 4 (-15V) and Pin 7 (+15V) and replace if necessary.
6. Biasing Trimpot has not effect. Replace the 2N4401 transistor next to the TRIMPOT.

16

Maintenance

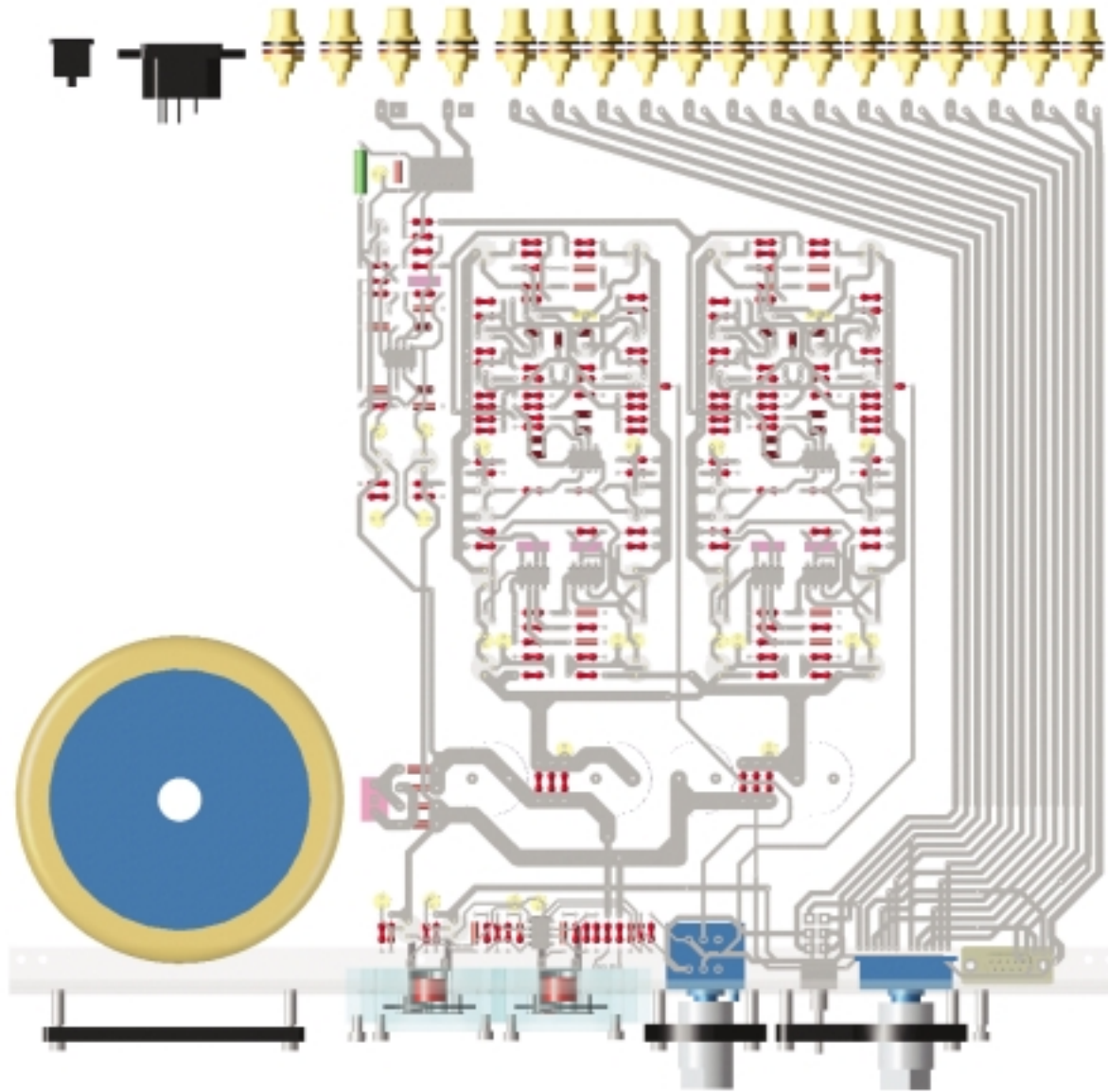

Schematic

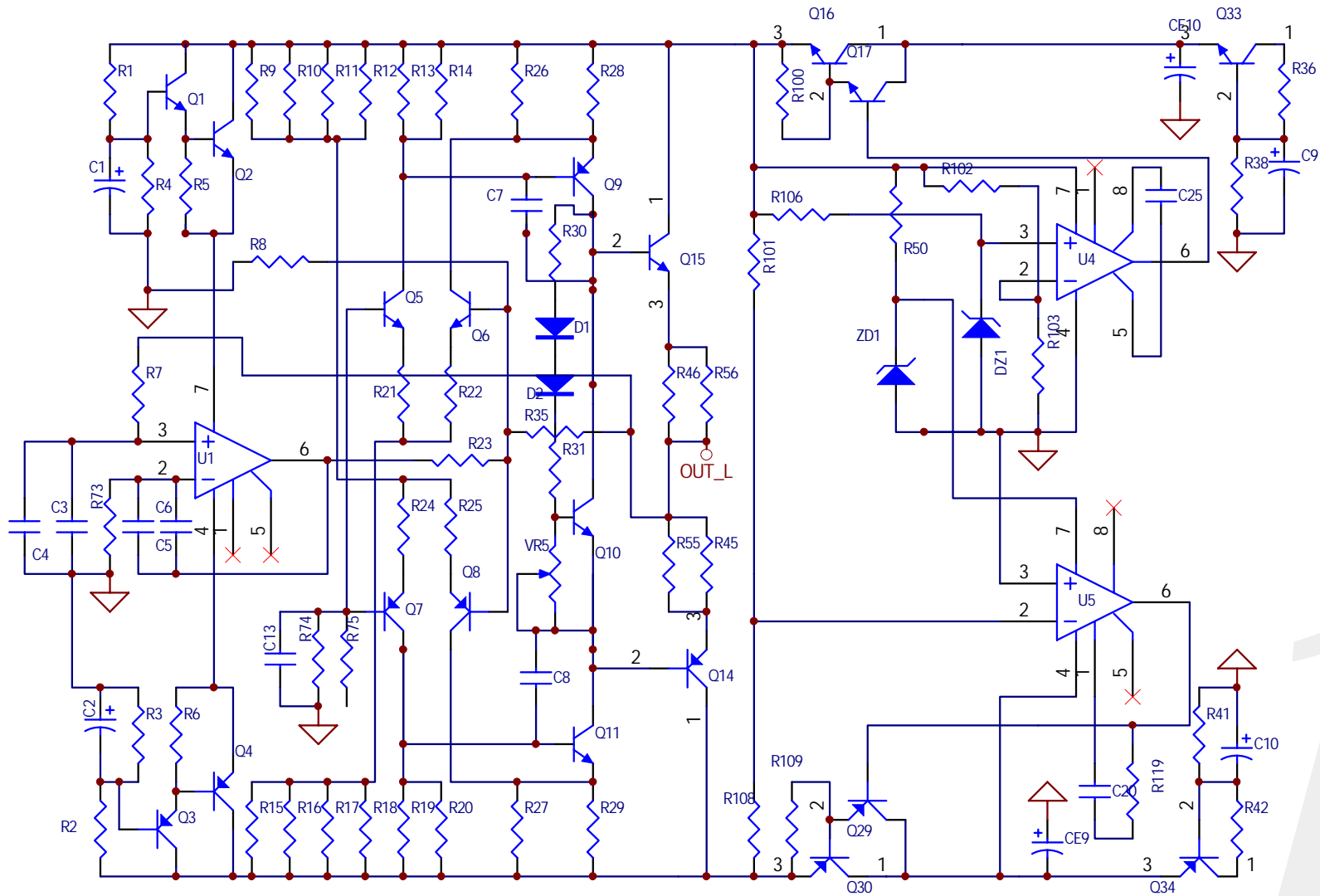

18

EC Declaration of Conformity to Appropriate Standards

S a f e t y

HD 195-S6

EN 60 065

E M C

Emissions Tested to EN 55013

Sound and television broadcast
receivers and associated equipment

Immunity Tested to EN55020

Electromagnetic immunity of
broadcast receivers and associated equipment

In accordance with

CISPR 16-1

Radio disturbance and immunity measuring apparatus

CISPR 16-2

Methods of measurement of
disturbances and immunity

IEC 801-2)

IEC 801-3 3V/m 20dB

IEC 801-4 1KV (AC lines)



Manufacturer

Metaxas Audio Systems
1460 Woodend Rd
Romsey 3434
Victoria AUSTRALIA
www.metaxas.com
metaxas@netspace.net.au
FAX: +613992 36481

Product

Metaxas Charisma Preamplifier



Design Philosophy

20

K O S T A S M E T A X A S D E S I G N