

# *Ikarus*

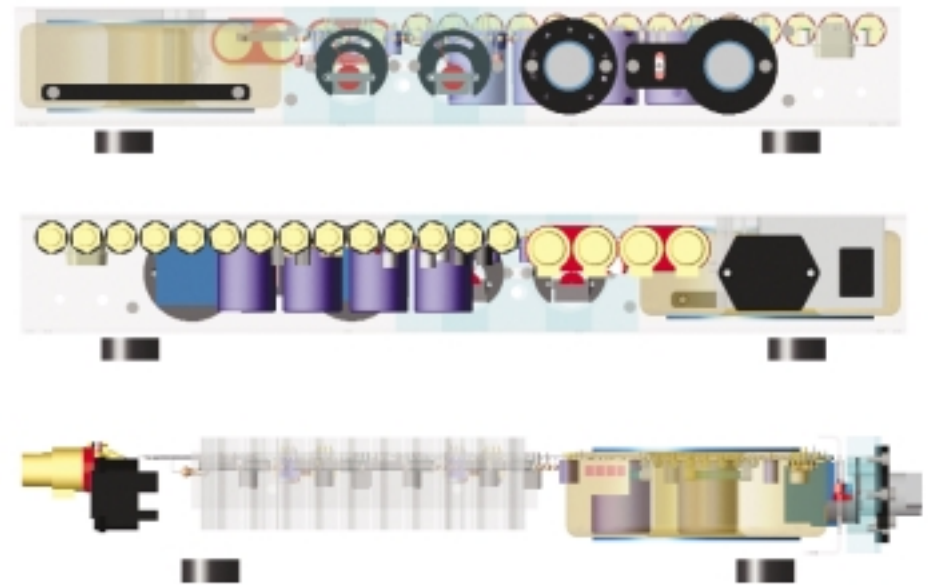

K O S T A S M E T A X A S D E S I G N

# *Contents*

<i>Awards &amp; Innovations</i>	<i>01</i>
<i>3 Decades of "Hi-End"</i>	<i>02</i>
<i>Listening Reference</i>	<i>05</i>
<i>Design Philosophy</i>	<i>06</i>
<i>Operating Instructions</i>	<i>11</i>
<i>What the critics say...</i>	<i>12</i>
<i>Specifications</i>	<i>14</i>
<i>Controls &amp; Features</i>	<i>15</i>
<i>Maintenance</i>	<i>16</i>
<i>Schematic</i>	<i>18</i>
<i>EC Conformity</i>	<i>19</i>

# Awards & Innovations

You are about to listen to an amplifier which has evolved from over 20 years of dedicated listening and the application of the state-of-the-art in every process of design and manufacture. I'm sure you'll enjoy listening to it as much as I do.

-Kostas Metaxas DESIGNER



*2 X AUSTRALIAN EXPORT AWARD, BHP STEEL DESIGN AWARD,*

*runner up in AUSTRALIAN SMALL BUSINESS AWARDS*

*First - Amplifiers- No wire construction with*

*shortest possible signal path*

*First - 'Capacitorless' circuits in Audio design*

*First power amplifier can put full power into*

*8 ohm load at 1.0MegaHertz!*

*(refer to article in USA "AUDIO").*

*First - High Speed diodes in power supply*

*First - DAC to use lowest jitter 'APOGEE CLOCK'*

*First - FULL range and high efficiency electrostatic*

*First - Audio Manufacturer to use BMW-Porsche CAD-PCB*

*software design systems*

# 3 Decades of Hi-End : 1980's

*Opulence Preamplifier*



*Assembly*



*Engraving*



*Ecstatic & Revelation Electrostatics*



*Kostas Metaxas circa 1985*



*Soliloquy Monoblocks*



# 3 Decades of Hi-End : 1990's

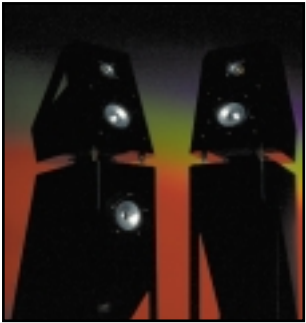

*Apollo Speaker*

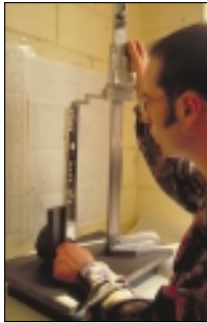

*Stainless Steel Turret Punching*



*Empress Full-range electrostatics using plastic-composite moulded frame*



*Iraklis "on-test"*



*PCB design*



*EMPEROR Assembly*

*Reference System circa 1992*



*Assembly*



*Assembly*



*Opulence, Marquis & Charisma Preamplifiers*



*CZAR 2-way full range electrostatic*



# 3 Decades of Hi-End : 2000's

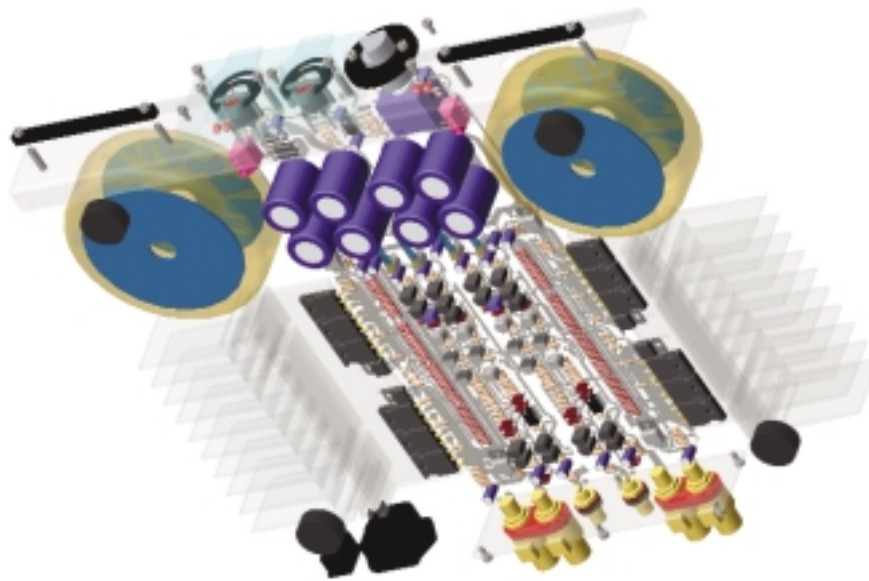

*Using technology borrowed from Aerospace and Formula 1, the new Kostas Metaxas Audio designs reflect the extraordinary advances that have been made recently in modelling and simulation software.*

*For the first time, a High End Audio manufacturer offers audiophiles a rare glimpse into the conception, design and execution of a complete product on a component by component basis in 3D.*

*The Protel PCB software [[www.protel.com](http://www.protel.com)] extends the quite normal listening tests on a component by component level to the PCB level.*

*Schematic Based simulations can test [or verify] the PCB's signal integrity by running the "Signal Integrity Simulator" which displays a Reflection and Crosstalk Analysis. And the 3D visualization allows one to include the PCB as part of the overall wholistic design.*

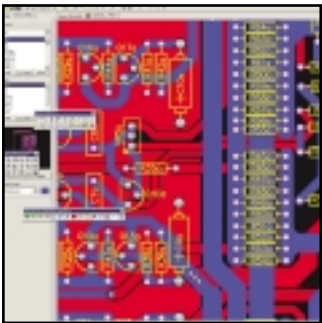

*Schematic Capture & PCB design*

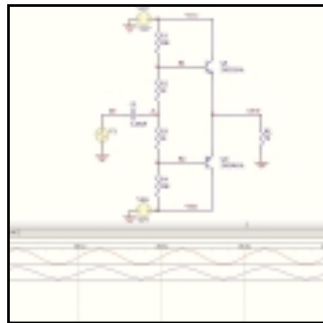

*Schematic "Spice" Circuit Simulation*

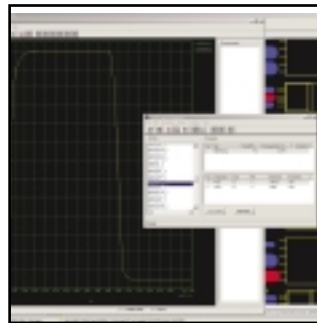

*PCB Track Risetime & Slewrate signal integrity testing.*

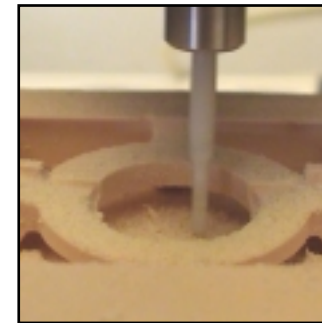

*In-house RAPID PROTOTYPING*



*Laser Engraving*

# *Listening Philosophy*

## REFERENCE



*The only way to design state-of-the-art audio equipment is to have first-hand experience with the finest available recording equipment AND playback equipment.*

*This is important for two reasons; it ensures that our designs work and 'mate-well' with other products and that their resolution is not limited by the weakest link in the playback 'chain'.*

*Kostas Metaxas products have been conceived using extensive listening tests with a variety of state-of-the-art ancillary equipment for more than 25 years.*

*Our amplifiers have been designed using a variety of state-of-the-art phono playback equipment and our ABSOLUTE REFERENCE - a custom-made battery-powered Stellavox SM-8 Tape Recorder using 1/4" tape at 30 ips and a Stellavox TD-9 using 1/2" tape at 30 ips specially calibrated for the Bruel & Kjaer 4003 1/4" omnidirectional electrostatic instrumentation microphones.*



# Design Philosophy

## ULTRA-SHORT SIGNAL PATH : NO-WIRE DESIGN

*A prominent audio designer once described an amplifier as "A straight piece of wire with gain". We take this further by featuring the **shortest** possible signal path in a commercial amplifier. We do not use wire in any of our signal paths and every component is directly soldered to one large printed circuit board.*

*From input to output, the signal passes through no more than 150mm of P.C. track. The transformer is connected with only 40mm of wiring to the PC board. This is only possible with our unique construction which features the complete amplifier (including filtering capacitors) is assembled onto one single rectangular Printed Circuit Board where the four sides connect directly to the inputs and outputs, power transistors on their heat sinks and power transformer.*

*The audio signal passes through **ONLY ONE TYPE OF WIRE** which is the high speed, wave controlled oxygen free copper of our PC board.*

## HIGH SPEED POWER SUPPLIES

*Every power amplifier uses a large, high-current power transformer which feeds a 'high-current' bridge rectifier to convert the AC from the transformer into DC voltages which are then mains ripple filtered using massive, computer grade capacitors.*

*The rectifier bridge that is normally used is relatively large, handles high current and low voltage which slow switching speed because of its inherent high internal capacitance.*

*It has a response time measured in milliseconds which if converted to frequency would mean that it would have a frequency response from DC to around 100Hz .*

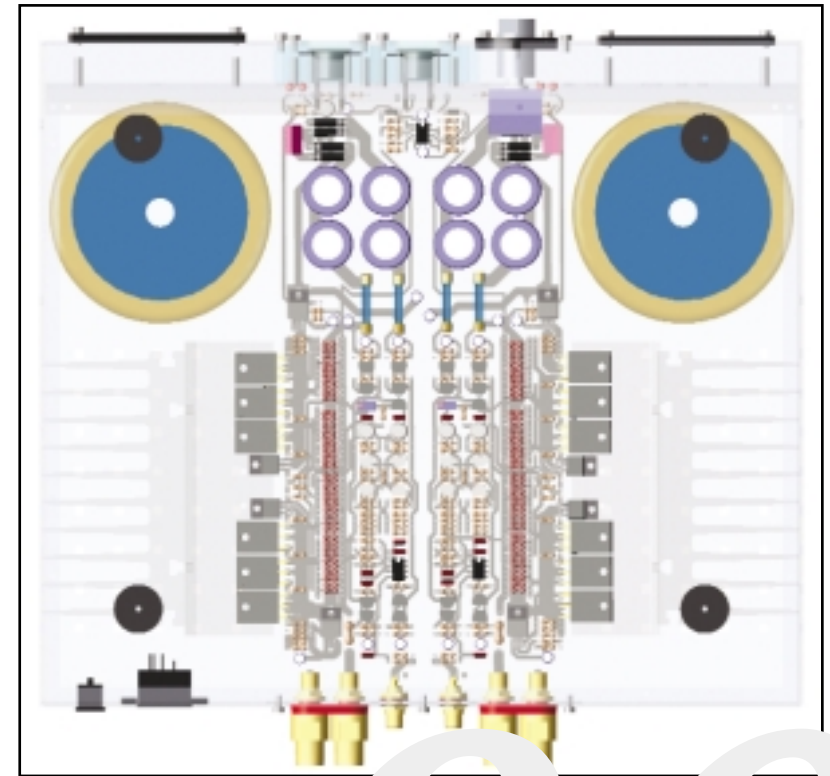

*Frequencies above 1 kHz would be unable to draw current instantaneously from the power transformer and would need to rely on the charge stored in the power supply filtering capacitors. We replace this slow DC rectifier with ultra high speed diodes wired in parallel with switching times in 'nanoseconds' which when converted to audio frequencies have a frequency response from DC-10 MegaHertz. High and low frequency currents can be drawn from the power supply more effortlessly .*

# Design Philosophy

## LOW NOISE, HIGH SPEED VOLTAGE REGULATOR DESIGN.

*The most significant difference between VALVE and TRANSISTOR circuits is the amplifier/power supply interaction.*

*In VALVE amplifier, the high voltages (from 200-400 Volts DC) result in a 50,000 to 100,000 Ohms value for resistor R. The equivalent transistor amplifier using much lower voltages (from 12-30 Volts) would have a substantially lower value of R between 200 Ohms-100 Ohms. Therefore a normal power supply in a transistor amplifier is more likely to affect the transistor amplifier circuit compared to a Valve amplifier circuit.*

*If we assume that the regulator impedance at V+ is around 2 Ohms just for the purpose of this illustration, then let us study the amplitude of the 10 VOLT sine wave as it goes through R and returns back to the OUTPUT of the TRANSISTOR circuit and VALVE circuit.*

*In the VALVE circuit, when 10 VOLTS travels across the 50,000 Ohms R towards the power supply impedance of 2 Ohms, the 10V signal is attenuated  $50,000/2 = 25,000$  times. Therefore  $10V/25,000 = 0.0004$  Volts of 1,0kHz sine wave.*

*On its way back to the OUTPUT of the circuit it is attenuated by the impedance of the amplifier (say 100 Ohms):  $0.0004 \text{ Volts}/50,000/1,000 = 0.000008$  Volts. Therefore, 0.000008 VOLTS of out of phase sine wave accompanies the 10 Volts sine wave as out-of-phase distortion in the VALVE CIRCUIT.*

*In a normal TRANSISTOR circuit, the 10 VOLTS going across the 200 Ohms resistor R would be attenuated only  $10/200/2 = 0.1$  VOLTS. On the way back to the output, the voltage is attenuated by:  $0.1V/200/1000 = 0.05$  VOLTS of out-of-phase sine wave added to the 10 VOLT output sine wave.*

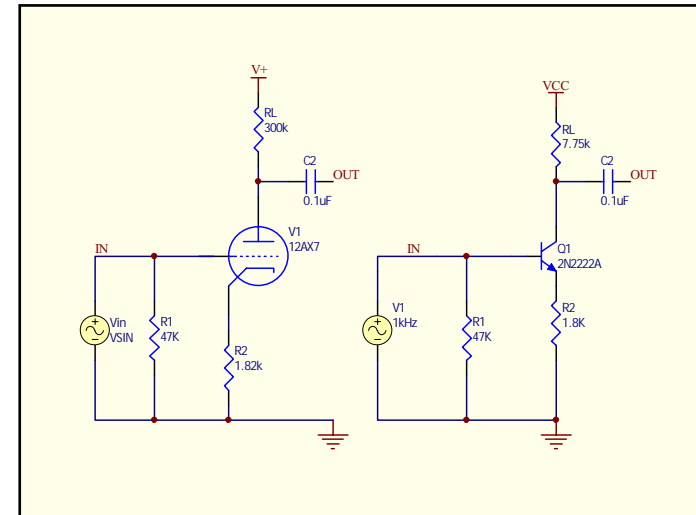

# Design Philosophy

*In a normal Transistor circuit, the 'phase distortion' is 0.5% as compared to 0.000008% for a normal VALVE circuit .*

*If we monitor the V+ point of the transistor circuit using an oscilloscope, we would notice this 0.1 Volts, 1.0 kHz signal. If we were to increase the frequency to 10,000 Hz and up to 1.0 MegaHertz the speed of dynamic behaviour of the power supply becomes critical. Using a normal I.C. regulator would result in the signal at V+ actually increasing in amplitude as the frequency increases to that at 1.0 MegaHertz the 1.0 Volt sine wave is now over 1.0 Volt!*

*To fully understand this interaction between the amplifier and power supply, it is necessary to understand how a voltage regulated power supply works. A voltage regulated power supply is essentially a D.C. amplifier (not unlike a normal power amplifier) which instead of having an audio signal at the input which is then amplified to become a larger audio signal at the output, has a fixed D.C. voltage reference at the input which is then amplified and becomes a larger DC voltage of at the output. The output impedance of the regulator, not unlike the output impedance (or "Damping Factor") of a power amplifier is less than one ohm at D.C.*

*If we use a 2.0 Volt zener diode as our fixed DC voltage reference at the input of the D.C. amplifier which has a gain of 10, the resulting output voltage is 20 Volts D.C.*

*The negative feedback loop of the amplifier which fixes the gain of 10 times the 2.0 Volt zener reference is very important because it maintains the output voltage irrespective; of an increase or decrease in the power supply voltage to the amplifier as long as there is a minimum voltage for the regulator circuit to operate (for a 12 Volt regulator, the minimum voltage is 15 Volts).*

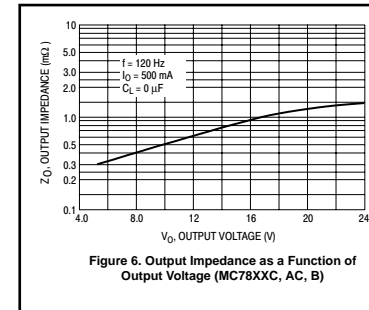

Figure 6. Output Impedance as a Function of Output Voltage (MC78XXC, AC, B)

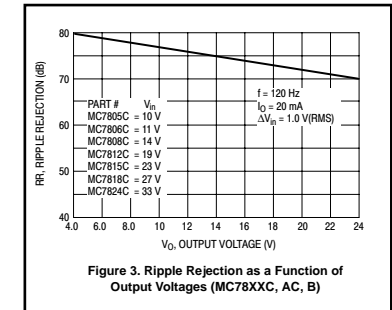

Figure 3. Ripple Rejection as a Function of Output Voltages (MC78XXC, AC, B)

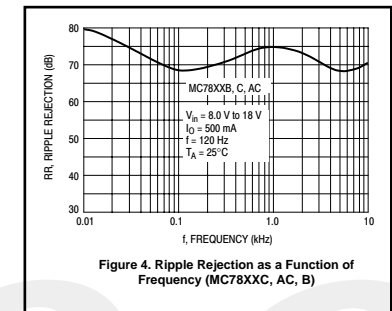
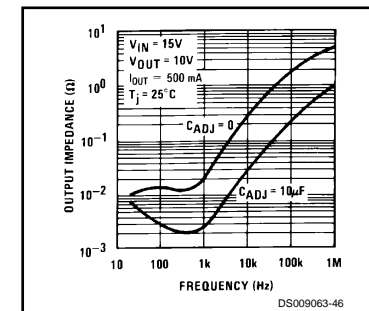

Figure 4. Ripple Rejection as a Function of Frequency (MC78XXC, AC, B)

# Design Philosophy

This is the STATIC performance of a voltage regulator which although important, does not affect the overall sound of the amplifier as much as the regulator's DYNAMIC performance which is influenced by the speed and 'open loop gain' of the regulator.

To understand why the Dynamic performance of a voltage regulator is so important, we need to go back to our basic amplifier circuit and investigate what happens to the 1.0 Hz, 10 Volt output signal as it goes across resistor R and encounters our voltage regulator.

To ensure an absolutely stable D.C. at V+ the residual of the 10 Volt sine wave at the OUTPUT is fed through the negative feedback loop of the regulator to force the amplifier to correct this error by applying an inverted signal identical to the residual sine wave to totally eliminate the residual sine wave at V+. A high speed regulator would therefore treat a signal 1.0 Mega Hertz in the same manner as a signal at 1.0kHz. The ultimate voltage regulator would effectively have a theoretical output impedance (or 'Damping Factor') at V+ of zero ohms at all frequencies as a result of its wide bandwidth before the addition of negative feedback.

In this way, the attenuation of the 10 Volts across the resistor R residual would be complete, and no attenuated component of the 10 VOLT sine wave could be deflected and return to the OUTPUT of the circuit and cause severe phase anomalies by adding to the new signal presented at the output - remember that it would take a few nanoseconds for the signal to go through the resistor and come back.

This extraneous out-of-phase information if allowed to add to the new OUTPUT signal, would then destroy TIME/PHASE characteristics of the amplifier circuit.

In real world power supply circuits, the impedance of the power supply actually increases with frequency because the open loop gain rolls off at high frequencies.

Marquis Voltage Regulator

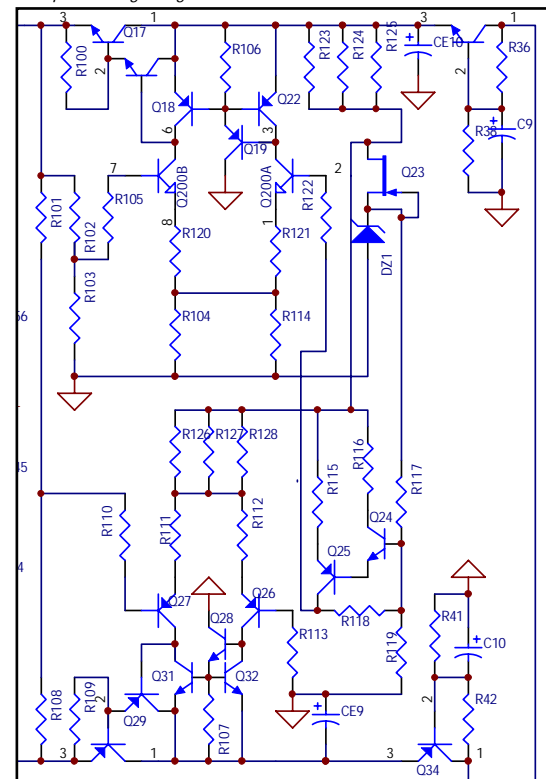

# Design Philosophy

*If we go back to our basic circuit and analysed the performance of an I.C. positive voltage regulator (say a LM78LXX from NATIONAL SEMICONDUCTORS) it would have an output impedance at the pin of its output lead of around 0.2 Ohms from DC to 10kHz, and then an increase to 0.4 Ohms at 20kHz, then 4.0 Ohms at 1 MEGAHERTZ which clearly illustrates the open loop frequency response has a turnover point around 10 kHz. When you add the normal distance between the regulator output and amplifier circuits which may be as little as 60mm to as much as 200mm in many circuits, the overall impedance increases 5 to 10 times. Also, to stabilise the operation of this I.C. regulator, it is essential to use an output capacitor for stability.*

*Clearly, this is not good enough for high performance, high speed transistor circuits. For this reason, we have approached the design of our regulators as PART of our amplifier circuits, rather than make the fastest amplifier circuit and add a slow I.C. voltage regulator with an output capacitor and call it a finished design. Our discrete voltage regulators are designed to have the absolute lowest noise, reject mains ripple, but more importantly to have a speed (1000 V/microsecond) which is a result of their wide bandwidth design (an open loop frequency response greater than 500kHz) and output impedance which is an order of magnitude better than any I.C. The regulator stability is achieved without ANY capacitors by varying the ratio between the local and overall feedback of each device.*

*We position the regulators within inches of the active circuits (in the case of the OPULENCE, the regulator is 3mm! from the active circuits) and the regulator impedance is flat from DC to beyond 5 MegaHertz at less than 0.05 Ohms.*

*Beyond this electrical design aspect, we listen to the sound of our regulators whilst developing each amplifier circuit to ensure that every component change or substitution produces an audible improvement from the selection of transistors to best biasing currents, choice of voltage references, zeners and degree of local feedback.*

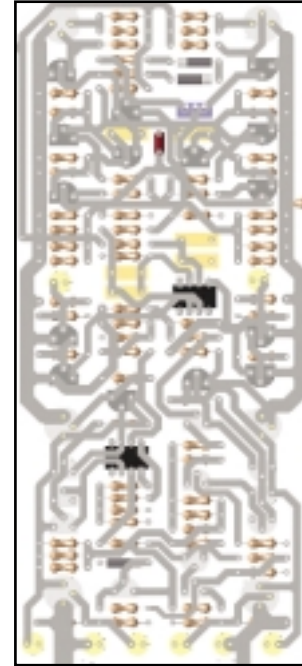

*Marquis "wholistic" approach to Line Stage/Regulator*

# *Operating Instructions*

## Steps for Connection

1. Ensure that the ON/OFF switch on the back panel is in the OFF position before connecting the amplifier into your system.
2. Once connected, ensure that there are no 'short circuits' in the speaker wires, then proceed to switch the unit ON.

Note: For the best results, it is recommended that the unit is powered on for at least 15 minutes before critical listening is attempted.

OPTIONAL PHONO STAGE - This needs to be installed BEFORE you take delivery of your amplifier. Please refer to the additional Instructions that come with the PHONO STAGE.

## Protection Circuits

The output stage of the amplifier is fused with +/- 2A fast blow fuses [M205 type] which protects the amplifier in case of operating faults. The low value of fuse inherently protects the following loudspeakers without the need for adding an OUTPUT RELAY.

## Mains Fuse

A 2AMP SLOW BLOW DA205 Type fuse is located on the AC MAINS SOCKET. If this blows, simply replace with the same rating fuse. If the fuse continues to blow, please refer to the Maintenance Section of this manual for further instructions.

## Serviceability

The complete active circuitry of the Iraklis including primary filtering capacitors are all mounted to the large single ground P.C.B. Easy access to the board is maintained by simply removing the base to gain access to the 'component side' to change a blown fuse.

# *What the critics say...*

*"It has taken little time for Australian firm MAS to receive worldwide attention . In France, the range of MAS Electronics has seduced us... Metaxas products belong to this rare category of electronics which achieve the essential and vital qualities of a good Hi Fi system which drive you to irresistibly listen and enjoy records one after the other".*

**Jean Hiraga/Patrick Vercher LA NOUVELLE REVUE DU SON, France.**

*"The IKARUS manages to combine two characteristics which are generally incompatible; on the one hand it succeeds in X-raying the music, whilst at the same time, it preserves its spirit and its musicality. The Ikarus is in fact an excellent product, rich in personality, refined, easy to use, very pretty, but most of all, it is a high class product.*

**Silvio Delfino FEDELTA DEL SUONO, Italy**

*" Provided that the back-up components are of good quality, listeners can expect lush, well produced sounds closely akin to vacuum tubes. The unit's presentation of a soundstage is astounding. All dimensions are faithfully reproduced with the appropriate focal impact. There is enough air around instruments and voices to beguile even seasoned listeners".*

**Ernie Fisher, THE INNER EAR REPORT, Canada.**

*"In my listening sessions, the IKARUS amazed me with what 40Watts can sound like. Mids were neutral and transparent and the highs were shimmering and detailed with neither harshness nor a hard gloss. The sound is astonishingly finely etched, even at very low volume levels. For sheer beauty (sonic and visual), uncharacteristically good connection flexibility and the ability to drive difficult audiophile speakers, the MAS IKARUS is the best 40Watter around".*

**Greg Borrowman, AUSTRALIAN HI FI, Australia.**

# What the critics say...

*"However I come to peace with myself by the sound of the IKARUS. The Australian neither oversearches for superfine details, nor omits any information. The IKARUS plainly serves the music. Searching carefully for its characteristic features, one notices that it produces an exceptionally broad soundstage in the listening room."*  
**Ulrick Michalik, HI FI EXCLUSIV, Germany.**

*"I'm surprised that this slim and simple appearance IKARUS integrated amplifier can perform almost perfect sound quality and high drive power. Output stage is normal class AB with 40WRMS into 8 Ohms, but with such a natural and clear performance, it sounds like class A. Even with its slim body, it drives speakers to loud levels with a vividness with fine energy levels from all frequencies".*  
**Mitsugu Kobayashi STEREO SOUND Japan**

*"On modern music (jazz , fusion and even rock), the IKARUS is very impressive. Its sound is correctly aggressive but at the same time warm and liquid; it captivates with the intense fascination of the sound it portrays. But it is with the late-night listening session at home with the volume control set just right so as not to disturb anyone, family or neighbours, that the IKARUS reaches the pinnacle of enjoyment. Joe Henderson breathes into the mouthpiece of his tenor sax 'Miles Ahead', the window is open to let a breath of fresh air in to take the place of the torrid daytime heat. Ah...tender is the night..."*  
**PierLuigi Sandonnini & Fabrizio Montanucci SUONO Italy.**

*"In contrast, the Metaxas presented more information especially 'in space'. Thanks to additional details and finer presentation, the IKARUS succeeded to demonstrate more clearly the characteristics of different recording techniques on a demo CD."*  
*RATING: Absolute Spitzenklasse IV REFERENCE (This is the highest rating for integrated amplifiers in German STEREOPLAY)*  
**Wilfried Kress, STEREOPLAY Germany.**

For full reviews, visit <http://www.metaxas.com>

# Specifications

The IKARUS is based on our successful IRAKLIS power amplifier schematic with an additional 10dB increase in overall gain. It acts as both line stage and power amplifier stage with only 6dB of negative feedback, eliminating an unnecessary amplifier circuit from the signal path.

Sporting the same overall construction quality of hand-engraved panels, machined stainless steel knobs, tiffany connectors, milspec double-sided oxygen-free copper PC Board and highly polished stainless steel case. Each IKARUS is individually numbered.

Using a complete dual mono approach in power supplies with separate individual high-speed rectifier diodes and almost 40,000uF of filtering supplies, only the large 200WATT toroid transformer is shared by both channels.

A high quality rotary switch and potentiometer (ALPS in this case) are the only components the signal encounters on its way to the high quality amplifier circuits, allowing an incredible wealth of fine musical nuance to pass directly through to the loudspeaker.

## Specifications

FREQUENCY RESPONSE : DC - 5.0MHz (-3dB)

POWER OUTPUT : 45WRMS per channel into 8 Ohms with no more than 0.05% T.H.D.

DAMPING FACTOR : Greater than 500 wide band

SLEW RATE : Greater than 1000V/us small and large signal

T.H.D. : Less than 0.05% 20Hz-20KHz

I.M.D.(S.M.P.T.E.) : Less than 0.05%

SIGNAL/NOISE : -117DBV unweighed input shorted

SENSITIVITY : 0.5VRMS in for 45WRMS out (35dB)

INPUT IMPEDANCE : 100kOhms in parallel with 11pF

# Controls & Features

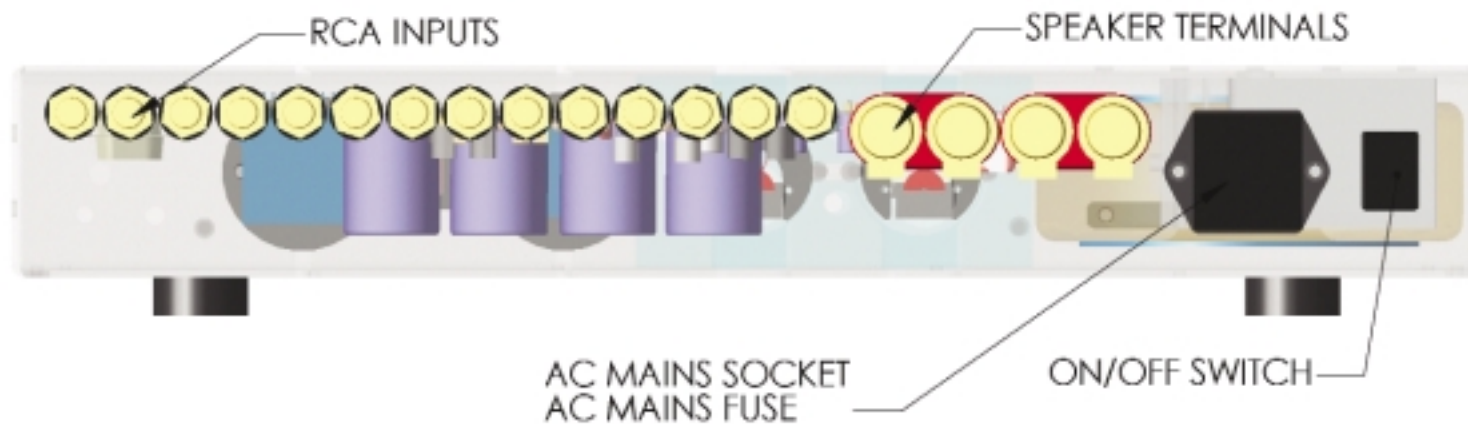
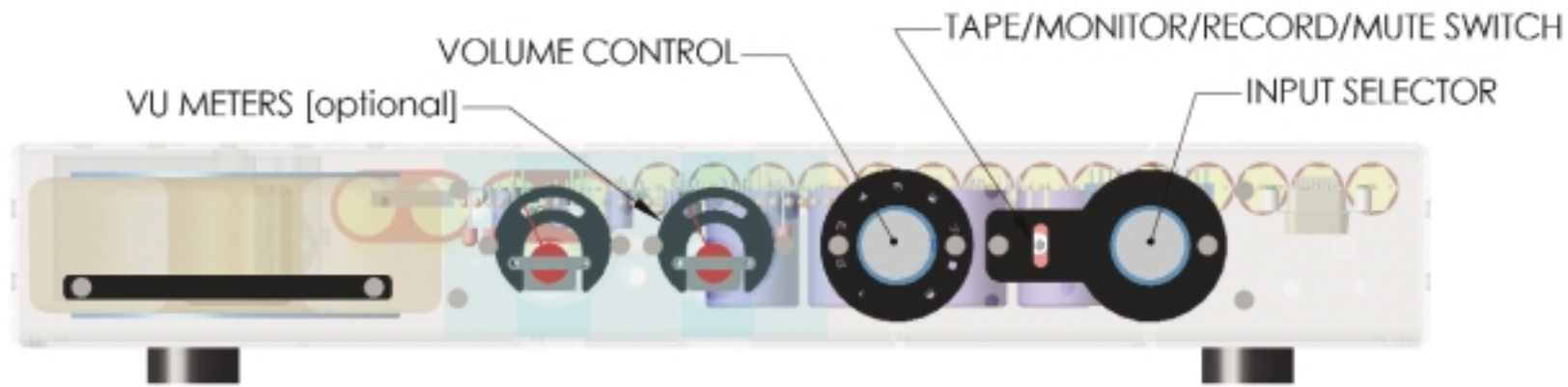

15

# Maintenance

## TESTING

1. Connect the + and - supply lines [at the FUSEHOLDERS or RECTIFIER DIODES] to an external current limiting Power Supply with maximum +/- 30VDC output voltage (or use 2 x 30VDC supplies).
2. Rotate the biasing trimpots VR5 & VR5a fully clockwise.
3. Connect the amplifier to a signal source (Sound Technology 1700B or Oscillator) which generates sine waves at 1.0kHz frequency and monitor the input and output on a dual trace Oscilloscope.
4. Power the module on (ensure that only 1.0 A fuses are installed for extra safety) and check that there is no current limiting. You should be able to monitor the amp on the Oscilloscope. (Connect your oscillator to any HIGH LEVEL input, and ensure that MUTING switch is in the UP position, and VOLUME control is at position 9).
5. Measure the voltage drop after the "capacity multipliers" [across the collector & emitter of Q19, 17, 19a 17a for the input stage and Q23,25,23a,25a for the output stage ]which should be -2 volts . If either the positive or negative series-pass transistors drop more than this voltage, check their VBE (voltage between the base and the emitter) and ensure that it is not more than 0.65V. If a greater value is measured, replace the faulty transistor.
6. If voltages are O.K. check the waveform on the oscilloscope, it should show crossover distortion.,
7. Clip a multimeter across any of the [20X] 10 OHMS output stage emitter resistors and turn the trimpot clockwise until you measure approx. 0.02 VDC across this resistor. Maintain for 30 minutes, adjusting the pot as the amp warms up.

## IF A FUSE BLOWS

1. Check the 30 OHMS resistors in series with the BASE of the output transistors [R49,39,40,59] to ensure that they have not "open circuited" - i.e. that they are not burnt.
2. Measure the DC resistance between any of the three leads of a power transistors Q14,15,22,24 or driver transistors Q12,13 [the transistors mounted on the heat sink bracket]. If you measure less than 100 Ohms between any two leads, then the device is faulty and must be replaced.
3. Connect the BLACK multi meter lead to earth and check for any short circuits on the positive or negative voltage rails.
4. If the MAIN FUSE blows then check the SF16 rectifier diodes DE5,6,7,8,9,10,11,12, for a short circuit. if they measure less than 100 Ohms, replace them.
5. DC Offset Voltage at Output. Connect multimeter probes to the BLACK and RED speaker terminals to measure the DC offset. It should be less than 0.05VDC. If it is greater than this please check the LF351 DC SERVO IC[U1]. Check that they are receiving voltage at Pin 4 (-15V) and Pin 7 (+15V) and replace if necessary.
6. Biasing Trimpot has not effect. Replace the 2N4401 transistor next to the TRIMPOT.

# Maintenance

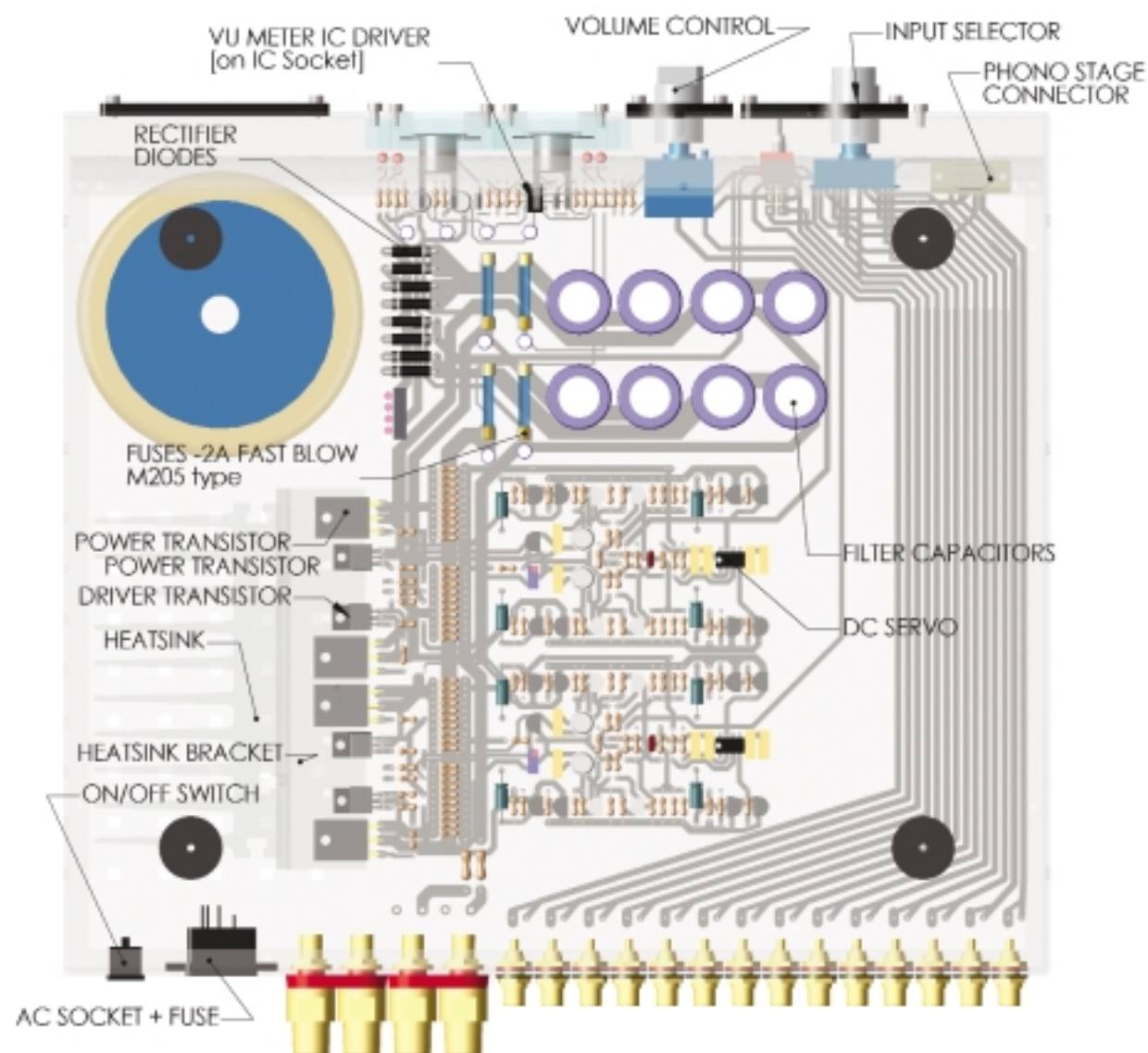

17



# EC Declaration of Conformity to Appropriate Standards

## S a f e t y

HD 195-S6

EN 60 065

## E M C

Emissions Tested to EN 55013

Sound and television broadcast  
receivers and associated equipment

Immunity Tested to EN55020

Electromagnetic immunity of  
broadcast receivers and associated equipment

In accordance with

CISPR 16-1

Radio disturbance and immunity measuring apparatus

CISPR 16-2

Methods of measurement of  
disturbances and immunity

IEC 801-2 )

IEC 801-3 3V/m 20dB

IEC 801-4 1KV (AC lines)



## Manufacturer

Metaxas Audio Systems  
1460 Woodend Rd  
Romsey 3434  
Victoria AUSTRALIA  
[www.metaxas.com](http://www.metaxas.com)  
[metaxas@netspace.net.au](mailto:metaxas@netspace.net.au)  
FAX: +613992 36481

## Product

Metaxas Ikarus Integrated Amplifier



# *Design Philosophy*

20

K O S T A S M E T A X A S D E S I G N